

Lê Quan Ninh

# Carbon-Based

for 4 percussionists

*dedicated to : Ensemble This Ensemble That*

2016

The piece has been imagined after having listened to the String Quartet No.2 by Jürg Frey

Stopwatches are necessary for the performance of the piece. All performers should begin their stopwatches at the same time. WiFi (or any other) synchronized stopwatches system is recommended

Each percussionist should be equipped with :

1 horizontal double-sided floor tom-tom or horizontal double-sided bass drum with the upper rim higher than the drum head

1 solid carbon rod with a diameter of 3 mm and a length of 1 m (can be a little bit shorter or longer)

1 doublebass bow

The carbon rod is bowed as being maintained on the drum head. The end closest to the hand is in contact with the drum head and the body is in contact with the rim. The longer part of the rod greatly exceeds the drum. It is bowed vertically close to the rim on the side of the instrument

In order to fulfill the playing instructions below, each percussionist determines independently the closest and the farthest possible playable contact points between the rod and the rim. Those are the positions ① and ④ as indicated in the score. Positions ② and ③ can be anywhere between positions ① and ④. The entire range is within a length of about 20/30 cm

The playing is as neutral as possible without any accent, neither at the beginning nor the end of each action. The percussionists have to pay attention to avoid - as far as possible - any fade in or fade out effects as well as to be quieter as possible when position is changed when not bowing. The sounds to be produced are close to the sound of a breath, a light pink noise, a breath colored by a pitch but note the opposite. The players should avoid getting clear pitches or creaking sounds.

Arrows (i.e. ① → ③ ) from a position to another one indicates glissandi obtained by sliding of the rod against the rim while bowing

The percussionists can be anywhere on stage or in the space. Can be played frontally or not. Not to be amplified though.

I

0'00" 12306 ms 0'21" 7785 ms

④ *pppp sempre*  
 ③ *pppp sempre*  
 ① *pppp sempre*  
 ③ *pppp sempre*

②  
 ①  
 ③  
 ③

II

0'42" 3000 ms 1'03"

③  
 ④  
 ④  
 ①

②  
 ①  
 ②  
 ②

II

15924 ms

1'24" 1'26" 1'28" 1'30" 1'32" 1'35" 1'39" 1'44" 1'51"

281 ms 366 ms 234 ms 456 ms 1020 ms 1790 ms 1085 ms 4813 ms 4490 ms

② ② ② ② ② ② ② ③ ③ ②

③ ③ ③ ③ ③ ② ② ① ① ① ① ④

④ ④ ④ ④ ④ ① ① ② ② ② ② ②

① ① ① ① ① ③ ③ ④ ④ ④ ④ ③

II

(1'57") 2'00" 6617 ms 2'13" 17797 ms 2'31"

7218 ms

③  
 ②  
 ③  
 ③

④  
 ①  
 ④  
 ②

④  
 ②  
 ②  
 ②

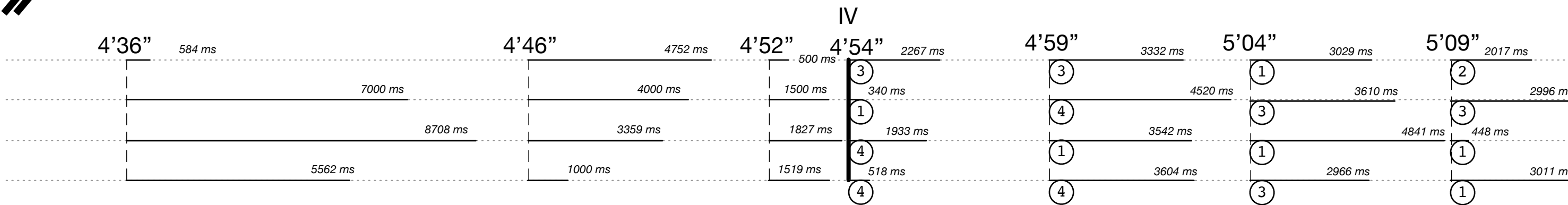
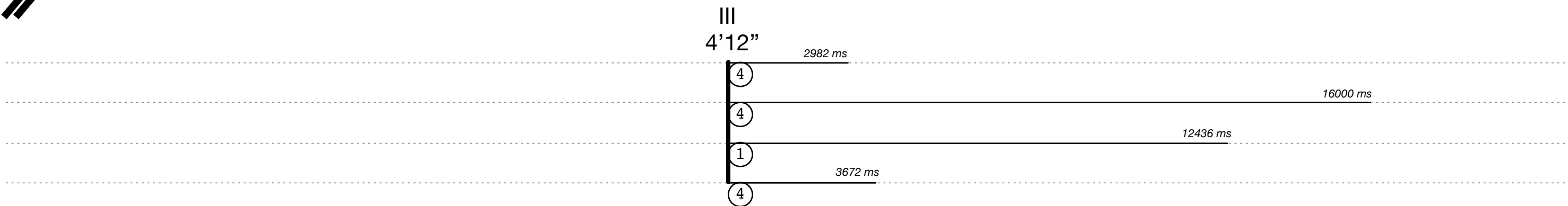
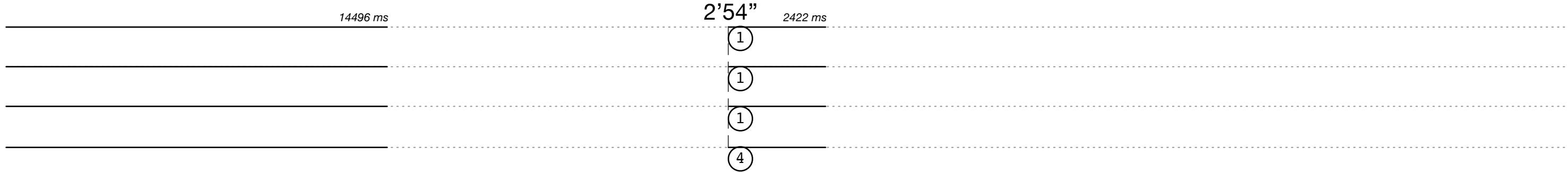

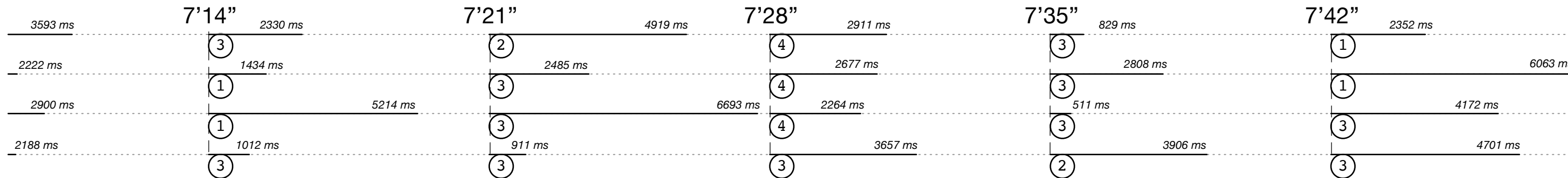
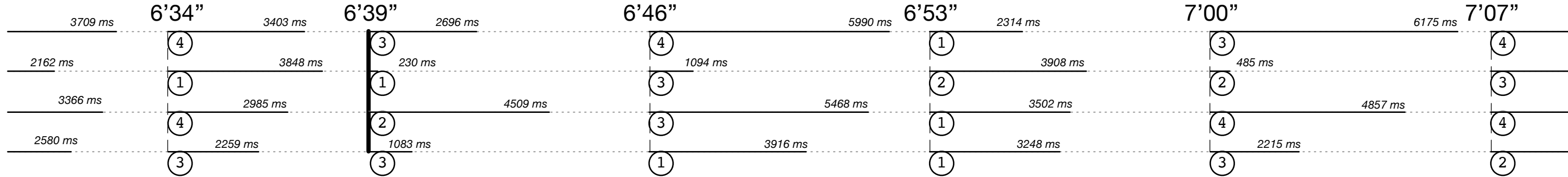
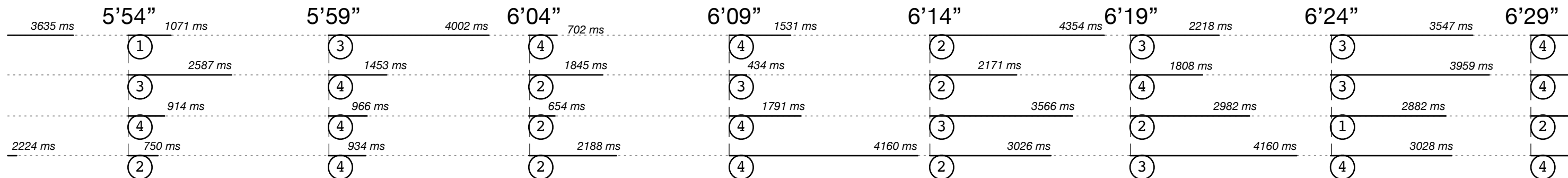
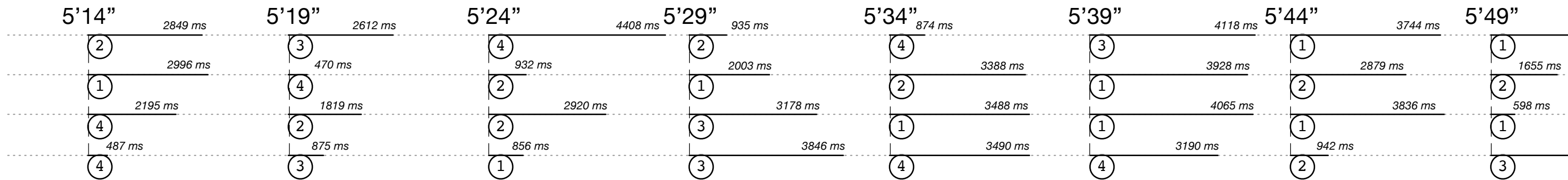

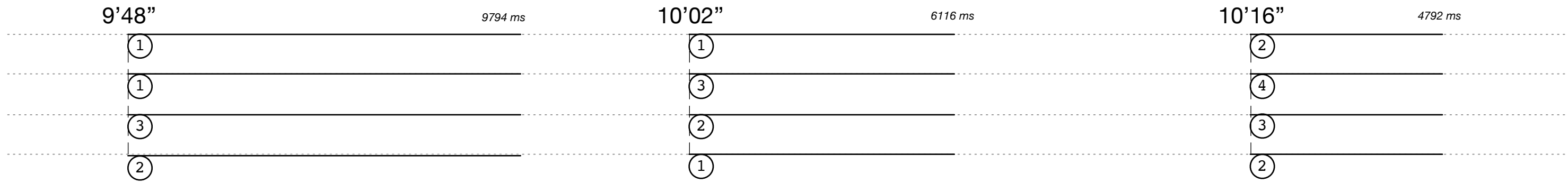
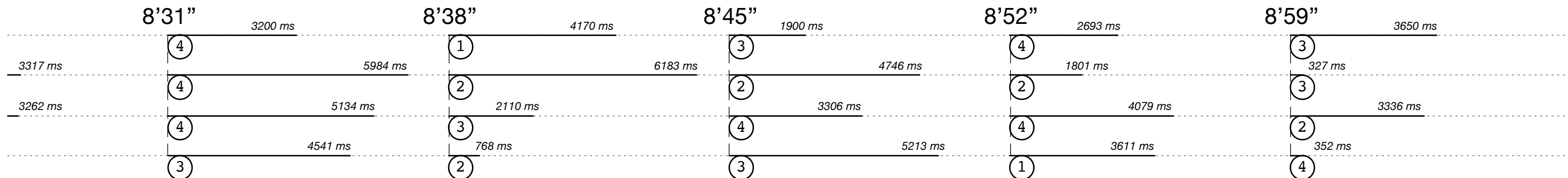
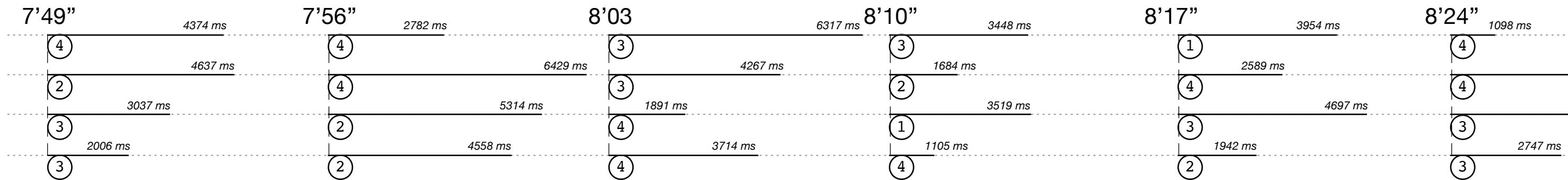

10'30"

10'44"

10'58"

3

13360 ms

3

1308 ms

2

2

2

2

1

3

1

3

1

3



12078 ms

11'12"

11'26"

9961 ms

11'40"

4

13282 ms

4

3

1

4

4

4

3

3

2

2

2



5288 ms

VII  
11'54"

(12'07")

(12'11")

18375 ms

3

+787 ms

3

2

3

(12'10")

4

3

+2022 ms

4

3



12'43"

4

4

2

4

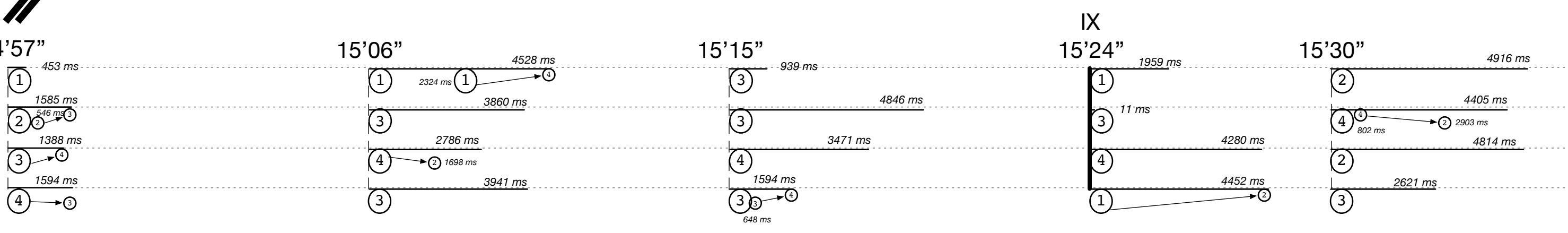
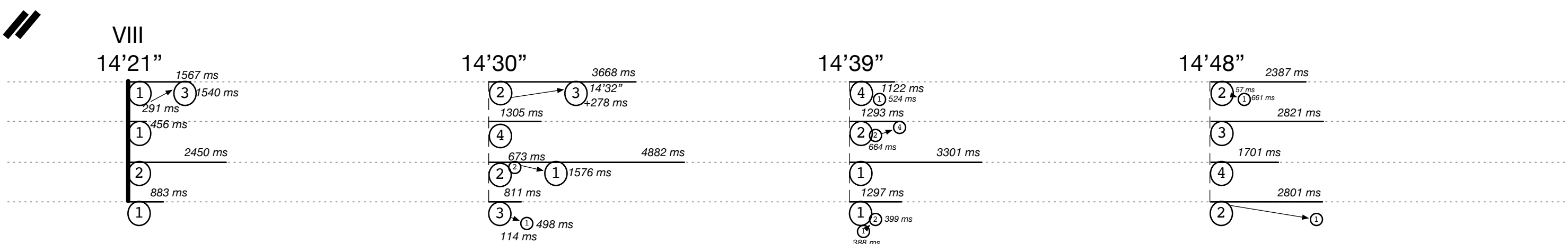
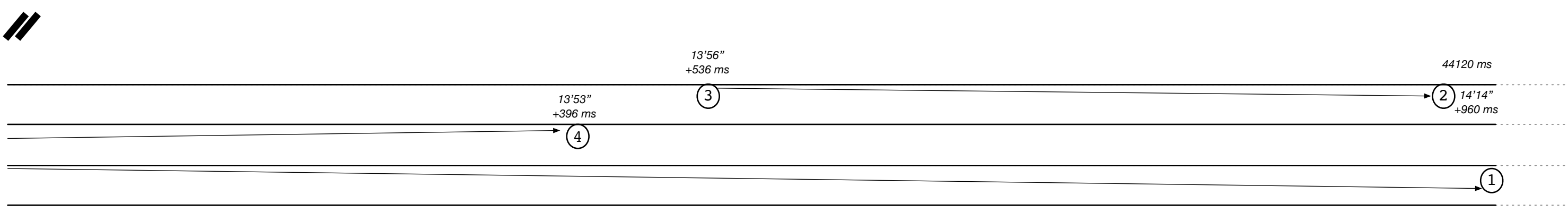



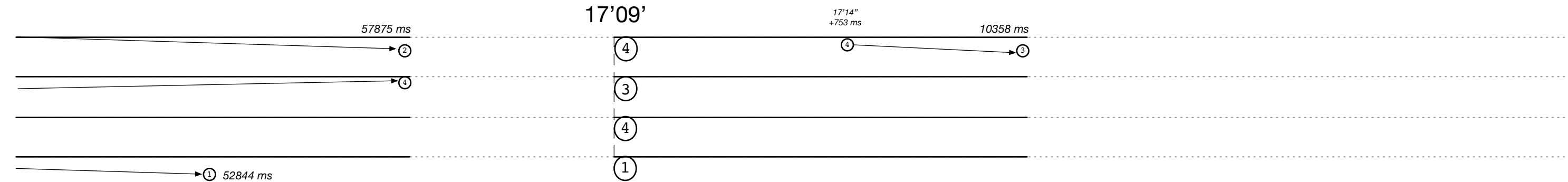
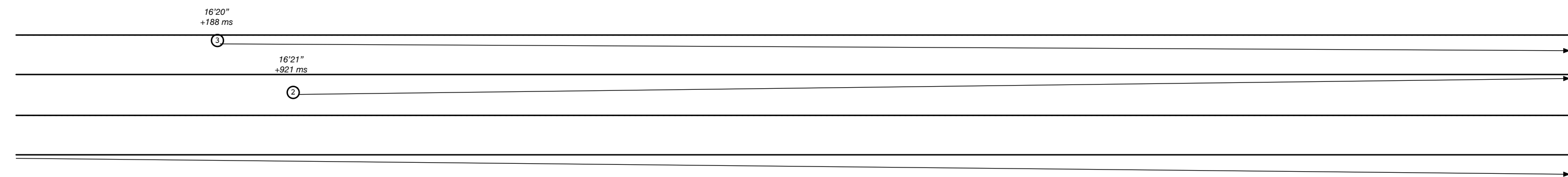
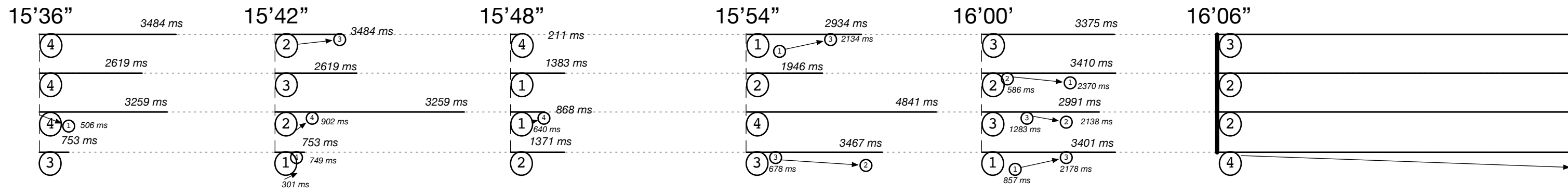

XI

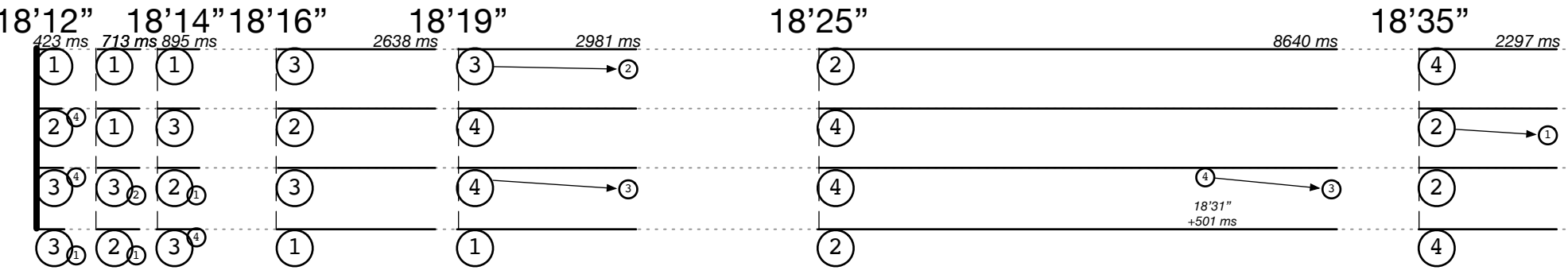

XII

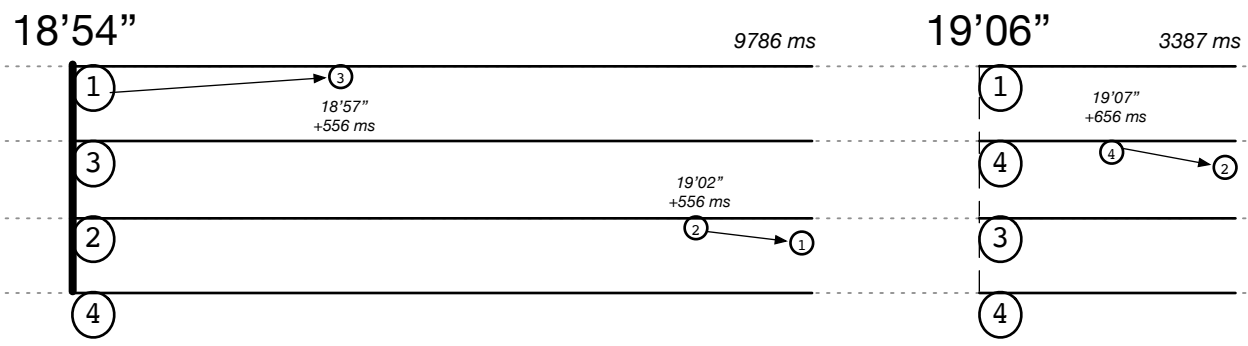

XIII

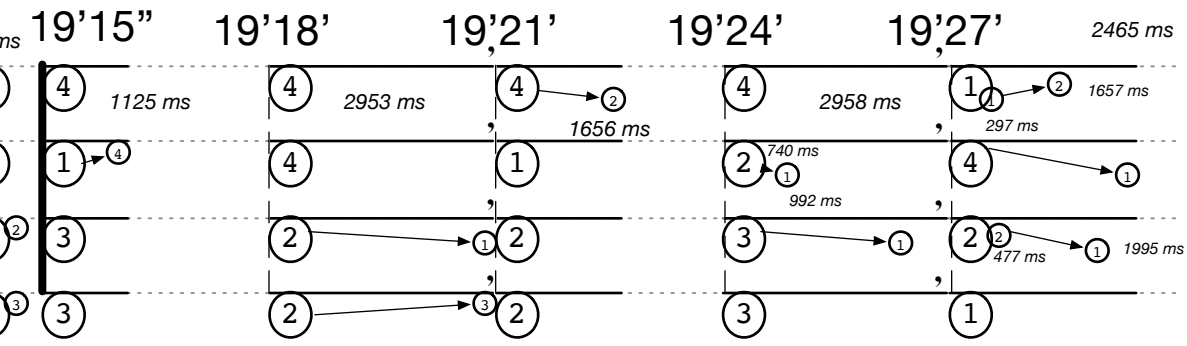

XIV

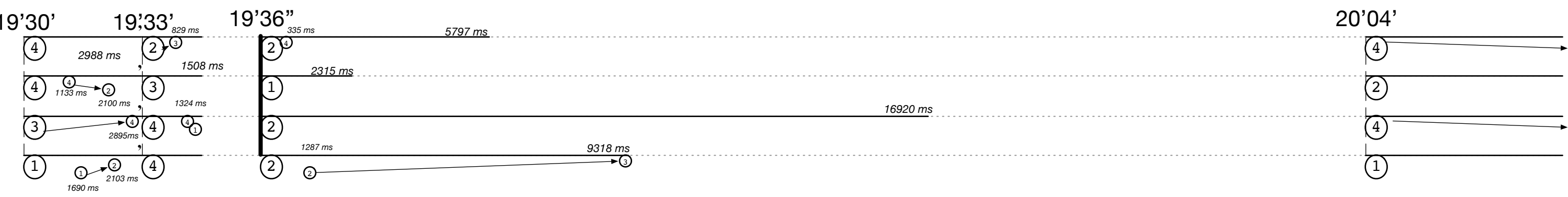

20'32'

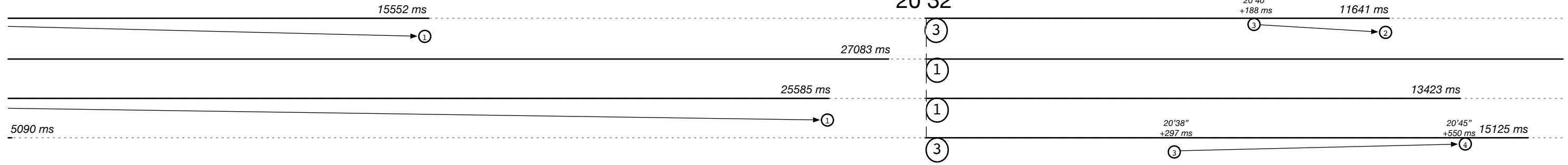

XV  
21'00"

10993 ms

21'17"

10000ms

18136 ms

①

②

③

③

③

21'05"  
+704 ms

21'07"  
+568 ms

②

③

①

21'24"  
+940 ms

①

③

③

③



21'34"

